

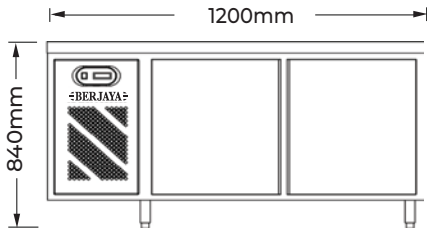

**INVERTER**  
**2DC4-IV-Z**

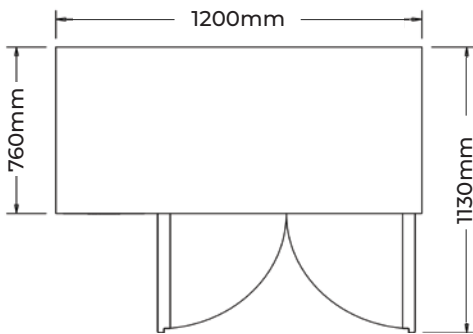

Front View



Top View

**2DC4-IV-Z**

### Product Features

- Inverter Compressor, low starting current, high energy efficiency, and low acoustic level with variable-speed technology
- Solid Door maintain the desired temperature inside the refrigerator, contributing to better energy efficiency.
- Effective counter-balanced weight system self-closing door provides smooth, even, positive closure.
- Durable stainless steel exterior and interior, Full-length door handle.
- Automatic defrost system saves energy consumption and provide the shortest possible defrost cycle.
- Ventilated System assisted with fan to ensure homogeneous coolness in the storage space.
- High-density Cyclo-isopentane Polyurethane insulated body saves energy.
- Environmental friendly refrigerant (R290 gas, fast cooling)

### Counter Chiller

Model	2 Solid Door	2DC4-IV-Z
Temperature °C (Celsius)		+2 to +8
Dimension (L x W x H) (mm)		1200 x 760 x 840
Gross Volume (Litres)		262
Voltage / Frequency (V/Hz)		230V / 1 / 50Hz 220V / 1 / 60Hz
Cooling Capacity (W)		221.5
Refrigerant		R290
Energy Consumption (kW/24h)		0.8
PVC Coated Shelving		4
Defrost System		Forced Air Circulation
Weight (kg)		77.5
Unit for 20ft / 40ft Container		22 / 46

# INVERTER ENERGY SAVING EFFECT

**74.68%**

**Reduced Energy Consumption**

- Laboratory Test in Cabinet Full Load Condition with Fridge Test M Pack as the figure shown.
- During the Laboratory test open the door every 10 minutes and hold for 6 seconds each time, simulating the usage method of end-user.
- Applicable test follow the ISO 22041 Standard.
- Actual Energy consumption is based on the actual operation and storage method from the end-user.

## Comparison of Energy Consumption

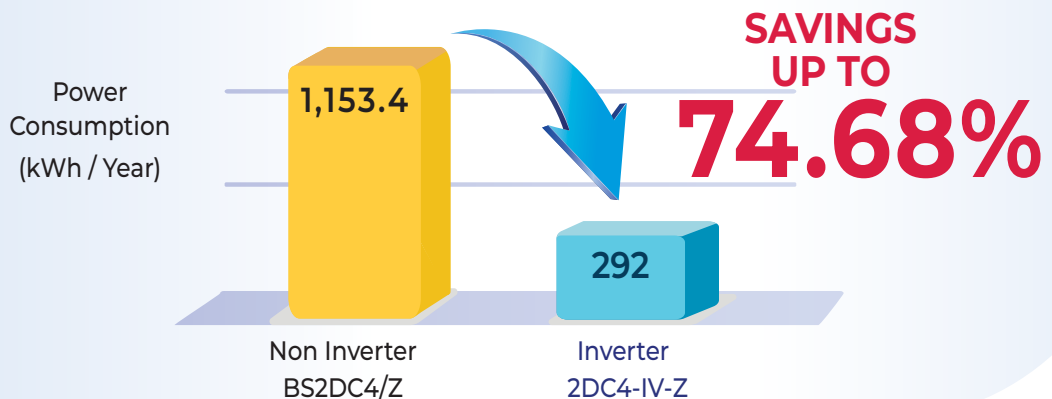

**12**  
EEI

**Energy Consumption Rating in MELS**

- Energy Consumption level based on Minimum Energy Performance Standard (MEPS) level at Energy Efficiency Index (EEI).
- Figure Table shown the Commercial Storage Refrigerators EEI Rating in Mandatory Energy Labelling Scheme (MELS) Tick Level.

## Energy Efficiency Index (EEI)

Mandatory Energy Labelling Scheme at

- ✓ - 1 Tick (Low) :  $80 \leq \text{EEI} \leq 95$
- ✓✓ - 2 Tick (Fair) :  $60 \leq \text{EEI} < 80$
- ✓✓✓ - 3 Tick (Good) :  $40 \leq \text{EEI} < 60$
- ✓✓✓✓ - 4 Tick (Very Good) :  $20 \leq \text{EEI} < 40$
- ✓✓✓✓✓ - 5 Tick (Excellent) :  $\text{EEI} < 20$

## Laboratory Test in Full Load Condition

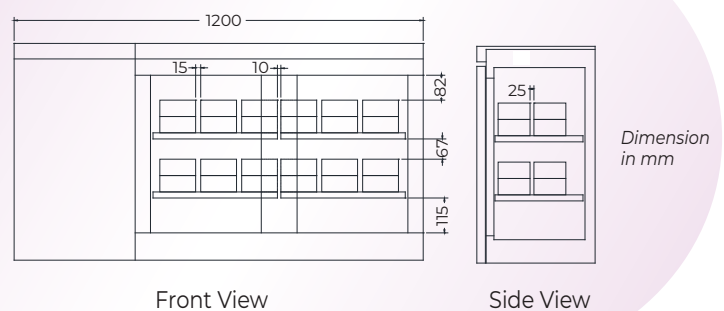

**within**  
**120**  
**mins**

**Higher Cooling Efficiency**

- Fast Cooling within 120 minutes in Full load Condition.
- Base on Temperature Controller Setting +2°C and Test in Environment Ambient Temperature 35°C.
- Laboratory Test in Cabinet Full load condition with Fridge Test M Pack as the figure shown.



**新馬白鋼雪櫃有限公司**  
**SINGMAH STEEL REFRIGERATION PTE LTD**