

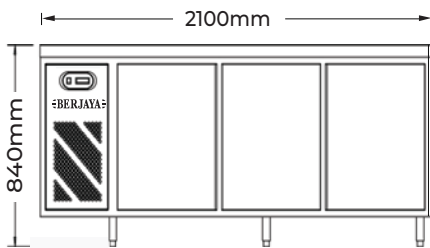

INVERTER
3DF7-IV-Z

Product Features

- Inverter Compressor, low starting current, high energy efficiency, and low acoustic level with variable-speed technology
- Solid Door maintain the desired temperature inside the refrigerator, contributing to better energy efficiency.
- Effective counter-balanced weight system self-closing door provides smooth, even, positive closure.
- Durable stainless steel exterior and interior, Full-length door handle.
- Automatic defrost system saves energy consumption and provide the shortest possible defrost cycle.
- Ventilated System assisted with fan to ensure homogeneous coolness in the storage space.
- High-density Cyclo-isopentane Polyurethane insulated body saves energy.
- Environmental friendly refrigerant (R290 gas, fast cooling)



Front View

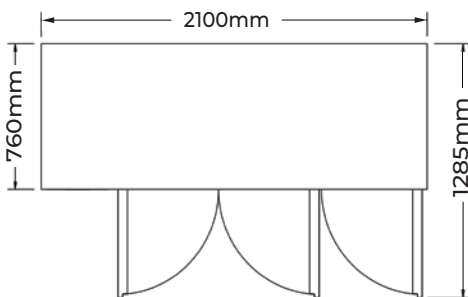

Top View

3DF7-IV-Z

Counter Freezer | 3 Door

Model	Solid Door	3DF7-IV-Z
Temperature °C (Celsius)		-18 to -12
Dimension (L x W x H) (mm)		2100 x 760 x 840
Gross Volume (Litres)		576
Voltage / Phase (V)		220 - 230V / 1
Frequency (Hz)		50 / 60
Cooling Capacity (W)		675
Refrigerant		R290
Energy Consumption (kW/24h)		4.4
PVC Coated Shelving		12
Defrost System		Forced Air Circulation
Weight (kg)		130
Unit for 20ft / 40ft Container		14 / 28

INVERTER ENERGY SAVING EFFECT

65.35%

Reduced Energy Consumption

- Laboratory Test in Cabinet Full Load Condition with Fridge Test M Pack as the figure shown.
- During the Laboratory test open the door every 10 minutes and hold for 6 seconds each time, simulating the usage method of end-user.
- Applicable test follow the ISO 22041 Standard.
- Actual Energy consumption is based on the actual operation and storage method from the end-user.

Comparison of Energy Consumption

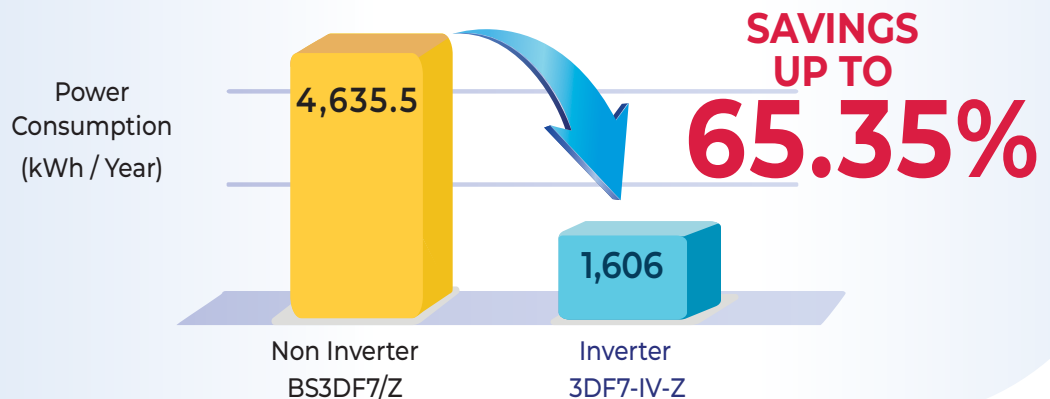

28.4
EEI

Energy Consumption Rating in MELS

- Energy Consumption level based on Minimum Energy Performance Standard (MEPS) level at Energy Efficiency Index (EEI).
- Figure Table shown the Commercial Storage Refrigerators EEI Rating in Mandatory Energy Labelling Scheme (MELS) Tick Level.

Energy Efficiency Index (EEI)

Mandatory Energy Labelling Scheme at

- ✓ - 1 Tick (Low) : $80 \leq \text{EEI} < 95$
- ✓✓ - 2 Tick (Fair) : $60 \leq \text{EEI} < 80$
- ✓✓✓ - 3 Tick (Good) : $40 \leq \text{EEI} < 60$
- ✓✓✓✓ - 4 Tick (Very Good) : $20 \leq \text{EEI} < 40$
- ✓✓✓✓✓ - 5 Tick (Excellent) : $\text{EEI} < 20$

Laboratory Test in Full Load Condition

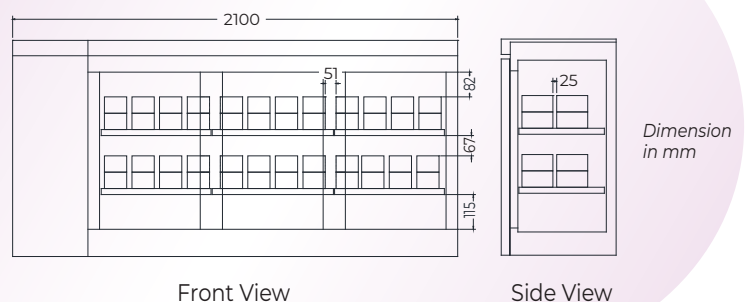

within 120 mins

Higher Cooling Efficiency

- Fast Cooling within 120 minutes in Full load Condition.
- Base on Temperature Controller Setting -18°C and Test in Environment Ambient Temperature 35°C .
- Laboratory Test in Cabinet Full load condition with Fridge Test M Pack as the figure shown.



新馬白鋼雪櫃有限公司
SINGMAH STEEL REFRIGERATION PTE LTD